

Notes  
Please refer to Table 1 'Tree inventory for Castlake SHD, Carrigtwohill, Co. Cork.' when reading this plan

Link to Train Station as part of Carrigtwohill to Midleton Inter-Urban Cycleway- Phase 1

Future Shared Access Link via Existing Underpass

Link to East/West connection road as part of Carrigtwohill to Midleton Inter-Urban Cycleway-Phase 1

Carrigtwohill Education Campus - To be Constructed by others

The above displays an example of a suitable protective barrier as recommended by BS. 5837 2012 Trees in Relation to Construction

1. Standard scaffold poles
2. Uprights to be driven into the ground
3. Panels secured to uprights with wire ties and where necessary standard scaffold poles
4. Weld mesh wired to the uprights and horizontals
5. Standard clamps
6. Wire twisted and secured on the inside of fencing to avoid easy dismantling
7. Ground level
8. Approx. 0.6m driven into the ground

Rev.	Date	Description

**Legend:**

- **Category (A, A1, A2, A3)**  
Those of high quality and value: in such a condition as to be able to make a substantial contribution (a minimum of 40 years)
- **Category (C, C1, C2, C3)**  
Those of low quality and value: currently in adequate condition to remain until new planting could be established (a minimum of 10 years) or young trees with a stem diameter below 150mm
- **Category (B, B1, B2, B3)**  
Those of moderate quality and value: those in such a condition as to make a significant contribution (a minimum of 20 years)
- **Category (U)**  
Those in such condition that any existing value would be lost within 10 years and which should, in the current context, be removed for reason of sound arboricultural management

**AGE GROUPINGS**

- Y = YOUNG
- MA = MIDDLE AGE
- M = MATURE
- OM = OVER MATURE
- V = VETERAN

- 1 EXISTING TREE CANOPY BASED ON DIMENSIONS GATHERED ON SITE IN 4 DIRECTIONS, NORTH, SOUTH, EAST AND WEST
- 2 ROOT PROTECTION ZONE BASED ON 12 TIMES THE (DBH) AT CHEST HEIGHT
- 3 TREE TAG NUMBER
- 4 TREE TO BE RETAINED
- 5 TREE TO BE REMOVED
- 6 TREE CATEGORY BASED ON BS:5837 2012 CRITERIA
- 7 DECIDUOUS TREE CANOPY
- 8 EVERGREEN TREE CANOPY

**01 TABLES BS 5837-2012**

**Key**

— FENCING

Client:  
Bam Property Limited

Project:  
Castlake SHD

Drawing Title:  
Tree Protection Plan (1of3)

Drawn By: RS	Checked By: MG	Date: 20/10/2021	Scale: 1:1000@A1
Dwg. No. CHD-TS-002a	CAD File: CHD-TS-002.DWG	Issued For: Information	Rev. -

Arbor Care  
Unit 2a  
Crossagalla Enterprise Centre  
Ballysion Road  
Limerick  
Ireland

Phone: +353 (0)863082808  
Fax: +353 (0)61400321  
Email: info@arborcare.ie  
Web: www.arborcare.ie

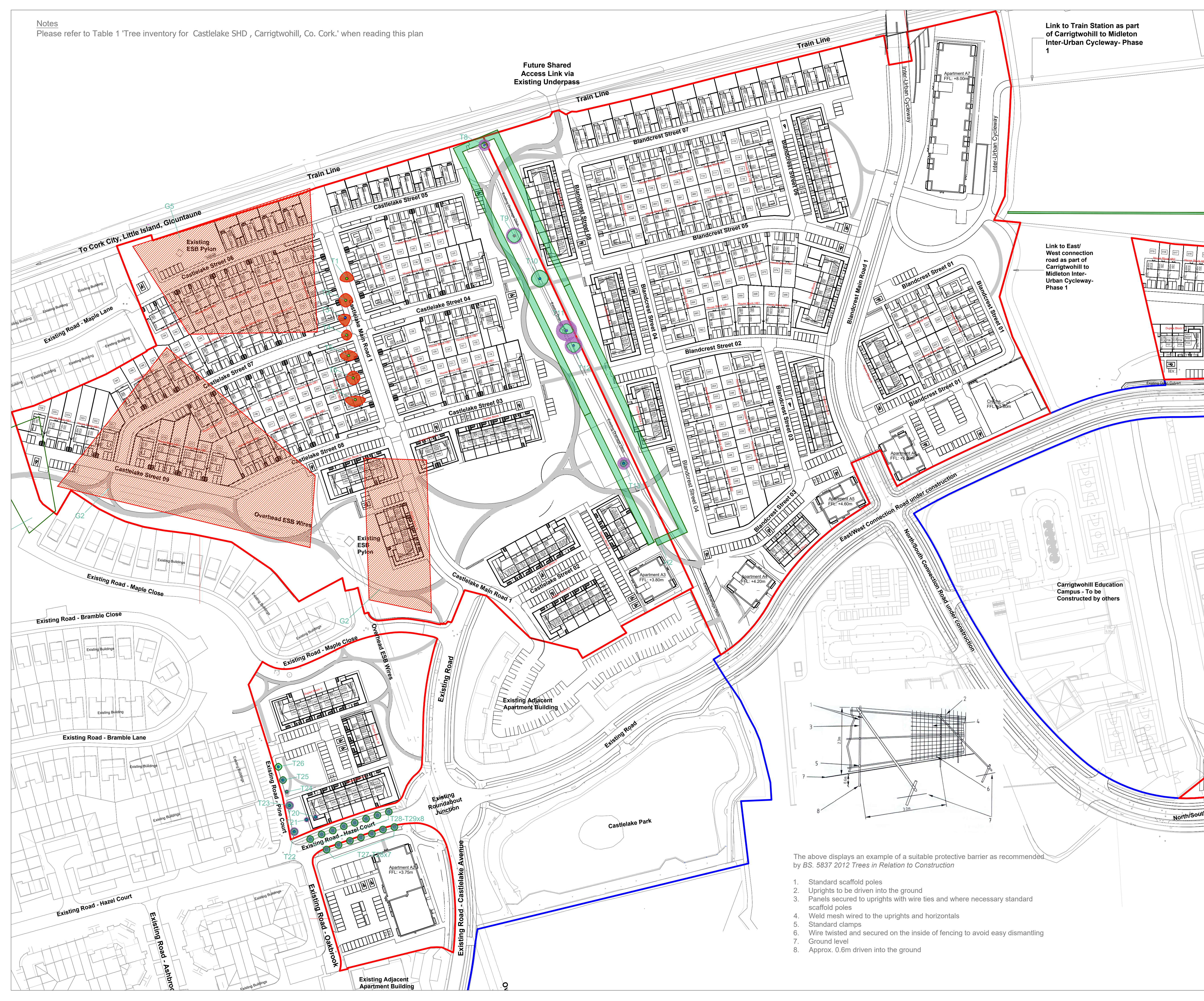



Notes  
Please refer to Table 1 'Tree inventory for Castllake SHD, Carrigwohill, Co. Cork.' when reading this plan

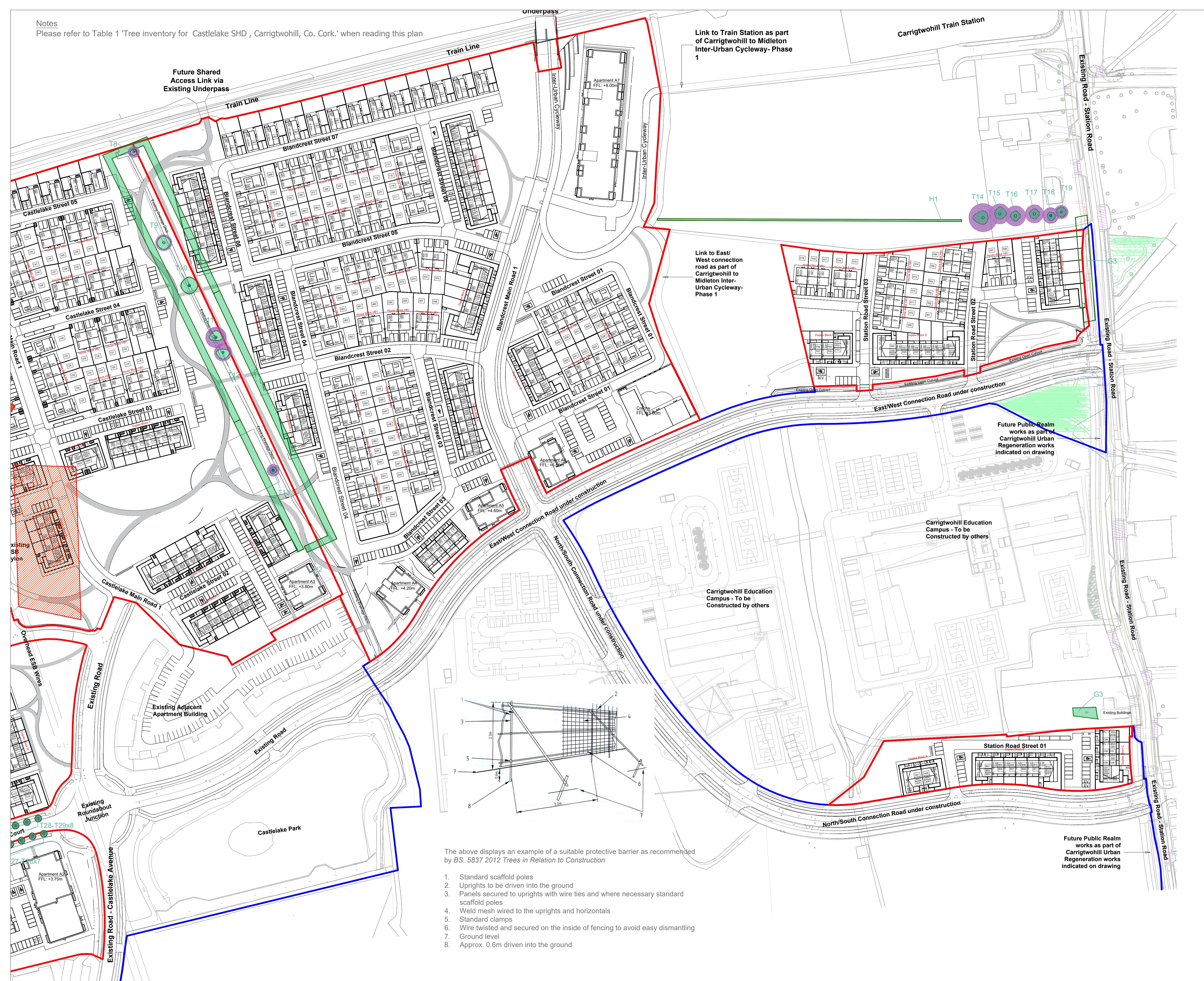

Rev.	Date	Description

- Legend:**
- **Category (A, A1, A2, A3)**  
Those of high quality and value: in such a condition as to be able to make a substantial contribution (a minimum of 40 years)
  - **Category (C, C1, C2, C3)**  
Those of low quality and value: those in such a condition that any existing value would be lost within 10 years and which should, in the current context, be removed for reason of sound arboricultural management
  - **Category (B, B1, B2, B3)**  
Those of moderate quality and value: those in such a condition as to make a significant contribution (a minimum of 20 years)
  - **Category (U)**  
Those in such condition that any existing value would be lost within 10 years and which should, in the current context, be removed for reason of sound arboricultural management

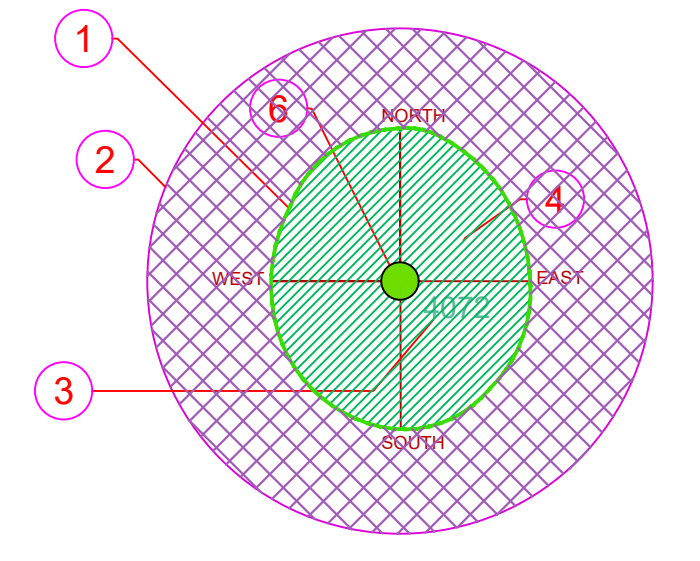

- AGE GROUPINGS**
- Y = YOUNG
  - MA = MIDDLE AGE
  - M = MATURE
  - OM = OVER MATURE
  - V = VETERAN

- 1 EXISTING TREE CANOPY BASED ON DIMENSIONS GATHERED ON SITE IN 4 DIRECTIONS, NORTH, SOUTH, EAST AND WEST
- 2 ROOT PROTECTION ZONE BASED ON 12 TIMES THE (DBH) AT CHEST HEIGHT
- 3 TREE TAG NUMBER
- 4 TREE TO BE RETAINED
- 5 TREE TO BE REMOVED
- 6 TREE CATEGORY BASED ON BS:5837 2012 CRITERIA
- 7 DECIDUOUS TREE CANOPY
- 8 EVERGREEN TREE CANOPY

**01 TABLES BS 5837-2012**

- Key**
- FENCING

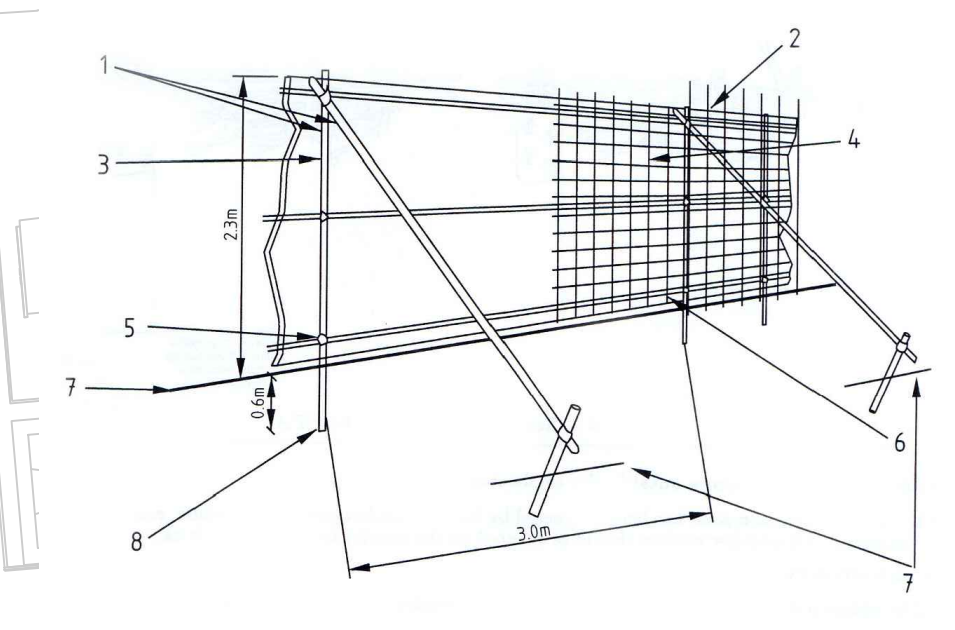

The above displays an example of a suitable protective barrier as recommended by BS. 5837 2012 *Trees in Relation to Construction*

- Standard scaffold poles
- Uprights to be driven into the ground
- Panels secured to uprights with wire ties and where necessary standard scaffold poles
- Weld mesh wired to the uprights and horizontals
- Standard clamps
- Wire twisted and secured on the inside of fencing to avoid easy dismantling
- Ground level
- Approx. 0.6m driven into the ground

Client:  
**Bam Property Limited**

Project:  
**Castllake SHD**

Drawing Title:  
**Tree Protection Plan (2of3)**

Drawn By: RS	Checked By: MG	Date: 20/10/2021	Scale: 1:1000@A1
Dwg. No. CHD-TS-002b	CAD File: CHD-TS-002.DWG	Issued For: Information	Rev. -

Arbor Care  
Unit 1a  
Crossagalla Enterprise Centre  
Ballysion Road  
Limerick  
Ireland

Phone: +353 (0)863082808  
Fax: +353 (0)61400321  
Email: info@arborcare.ie  
Web: www.arborcare.ie



